

GENSET CONTROL MODULE—LEVEL 0 B120C

Features:

- One model for both spark ignition and diesel engines.
- 5-alarm light outputs with automatic lamp-test provision.
- Overspeed adjustment not required.
- Factory selectable starting mode: single-cycle crank limiter (standard), or full cycle-cranking (optional).
- Factory selectable time delays for engine start and engine stop (cool down).
- Loss of speed signal protection for crank motor circuit.
- Special logic to re-establish cranking following a false start.
- Special logic permits re-starting of hot engine.
- Packaged for direct mounting to inside surface of customer control panel. Alarm lights project thru control panel for viewing by operator.

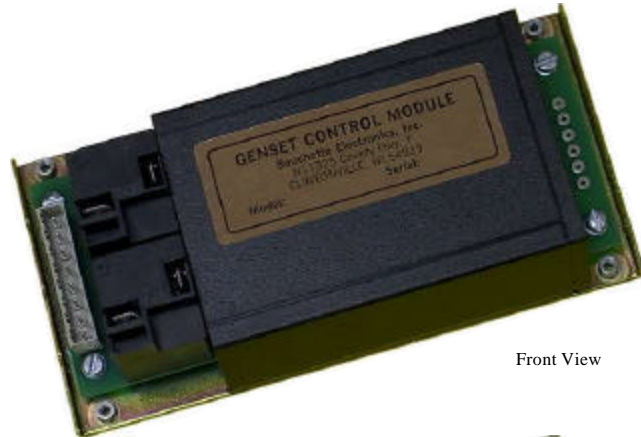

Front View

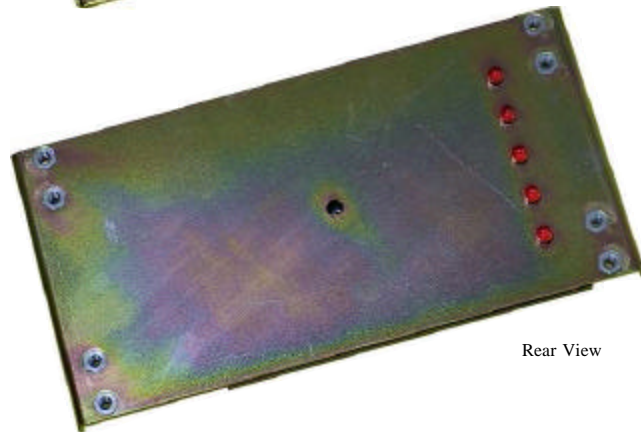

Rear View

B120C Control Module—Shown with optional plug-in type terminal block header.

General Description:

The Genset Control Module is a microprocessor based control system which provides complete automatic control of standby generator set engines. Fuel solenoid and/or ignition control, and cranking control are via heavy duty industrial type relay contacts. Engine temperature and oil pressure monitoring are obtained from engine mounted sensor contacts. Overspeed shutdown and crank termination control are provided internally via main generator frequency monitoring input terminals. One spare input and one spare output are available for special customer program requirements. Unless otherwise specified, this spare is shipped programmed as a 5th shutdown and alarm light output.

B120C Specifications

Input Voltage: 12VDC nominal, 16VDC max; transient and reverse polarity protected.
(Typical: Pickup at 10VDC, Dropout at 6VDC.)

Supply Current: 0.4A maximum.

Relay Load Contacts: 20A at 28VDC.

Shutdown Input Contacts: 3. (See operating instructions for start-up override times.)

Main Generator Frequency Input: 120VAC nominal, 150VAC maximum.

Overspeed trip point is fixed at 69Hz.

Crank disconnect is fixed at 16Hz. (Approximately 500 RPM).

Crank Control: Standard: Single-cycle crank limiter: continuous 48 second crank period (non-adjustable.)

Optional: Cycle cranking: 5 cycles of 12 second crank and 12 second rest (non-adjustable.)

Time Delays (optional): Delay on start from remote signal: 3 sec. (non-adjustable.)

Delay on shutdown from remote signal: 3 min. (non-adjustable.)

Lamp Test: Alarm lights are automatically tested each time engine is started.

Shielding: Internal EMI shielding provided.

Ambient Temperature: -25° F to +140° F

Finish: PC Board: Protected with moisture/fungus proof varnish.

Chassis: Zinc plated / yellow dichromate.

Cover: ABS plastic.

Terminal Blocks: Standard: Industrial vertical fixed compression type terminal block.

Optional: Industrial vertical plug-in type header for use with customer supplied socket connector, to ease wire harness assembly and installation:

8 point socket connector: Wieland #25.345.3853.0, Phoenix Contact #1792304 (Digikey #277-1046-ND)

Bouchette Electronics, Inc.

N11325 County Highway Y, Clintonville, WI 54929
(715) 823-7770 (715) 823-7771 Fax www.bouchette.com

B120C Dimensions

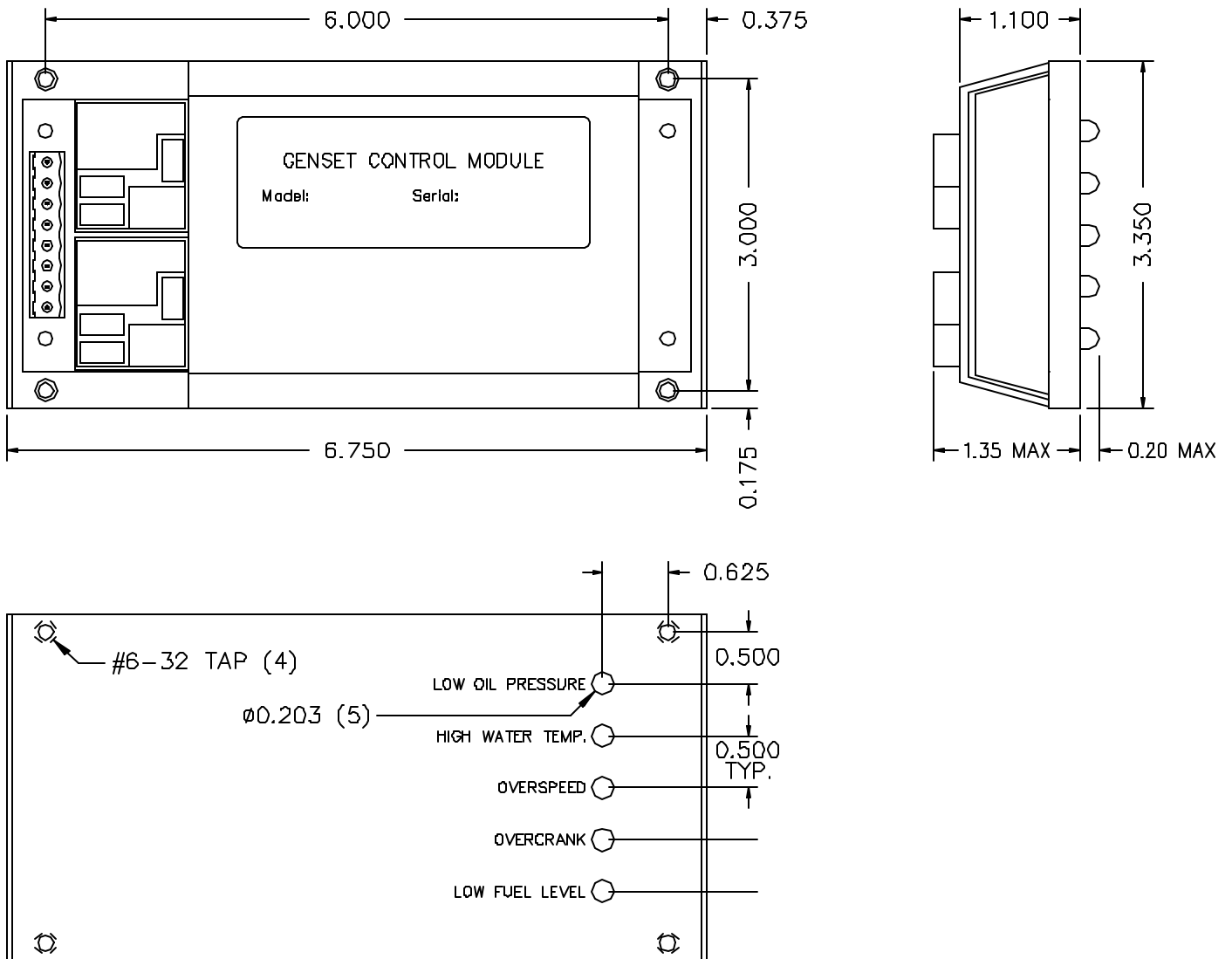

Bouchette Electronics, Inc.

N11325 County Highway Y, Clintonville, WI 54929
 (715) 823-7770 (715) 823-7771 Fax www.bouchette.com

GENSET CONTROL MODULE — LEVEL 0

A120C / B120C

Control Switch Inputs

The following operator panel controls are wired into the microprocessor through the front-mounted terminal blocks:

1. Run/Stop/Auto Switch.
 - a. “Run” position causes the engine to start and run immediately.
 - b. “Auto” position allows the unit to be controlled via any remote single-pole dry-type contact (transfer switch, remote start switch, etc.). Contact closure causes the unit to start and run, while contact opening causes the unit to shut down. *Also see Time Delay Select for time delay options.*
 - c. “Stop” position de-energizes the control module for immediate shutdown.

Lamp Test

The microprocessor automatically performs a lamp test routine each time the engine starts: All lamps illuminate immediately with the start signal, then extinguish one at a time at approximately 1-second intervals.

Relay Functions

1. Master Control Relay (FS).
Operates the fuel solenoid and/or ignition control.
2. Cranking Control Relay (CS).
Controls engine cranking functions.

Safety Shutdown Inputs

1. Low Oil Pressure (LOP) Shutdown.

Monitoring of oil pressure begins 12-seconds after the unit starts and remains in effect until the unit is shut down (*except as noted in section Microprocessor Program Notes.*) Except as noted, closure of this contact while engine is running results in an engine fault shutdown with alarm light indication. The LOP signal is derived from an oil pressure sensor switch mounted on the engine.

2. High Water Temperature (HWT) Shutdown.

The engine coolant temperature sensor monitoring begins immediately with the start signal. However, if the water temperature is excessive prior to start, (i.e., heat soak after shutdown), the unit is permitted to start and the high temperature condition is permitted to exist for up to 60-seconds after the unit is running, before an engine fault shutdown with alarm light indication occurs. If the high temperature condition is corrected within that time period, the microprocessor circuit reverts to normal monitoring. Except as noted, closure of this contact while engine is running results in an engine fault shutdown with alarm light indication. The HWT signal is derived from a temperature sensor switch mounted on the engine.

3. Low Fuel Level (LFL) Shutdown.

Monitoring of the fuel level input begins 12-seconds after the unit starts and remains in effect until the unit is shut down. Except as noted, closure of this contact while running results in an engine fault shutdown with alarm light indication. The LFL signal is derived from a fuel level sensor switch mounted on the fuel tank.

4. Overspeed (OS) Shutdown.

Overspeed shutdown protection is provided by a frequency sensing network within the control module. The OS signal is derived from a 120VAC winding of the main generator. The trip point of the frequency network is factory set at 69Hz. Exceeding this speed will result in an engine fault shutdown with alarm light indication.

Cranking Control

1. Overcrank (OC) Protection.

Two different cranking cycles are available from the factory for programming into the control modules microprocessor:

a. Single-Cycle Cranking Feature (Standard).

This feature provides a single, non-adjustable, crank period of 48-seconds. Failure of the engine to start within that time results in an “overcrank” engine fault shutdown with alarm light indication.

b. Cycle Cranking Feature (Optional).

This feature provide a series of five cranking cycles; each containing a 12-second crank period with a 12-second rest period. Failure of the engine to start by the end of the fifth crank period results in an “overcrank” engine fault shutdown with alarm light indication.

2. Cranking Disconnect.

The cranking termination speed is obtained from the frequency network within the control module. The microprocessor automatically sets the cranking termination speed at approximately 500 RPM.

3. Loss of Frequency Signal.

The microprocessor will detect an absence of frequency signal while cranking. After the first 12-seconds of cranking, the “overcrank” light begins a staggered flashing pattern to indicate there is no frequency signal input.

If the cycle cranking feature (*1.b above*) was selected; the microprocessor automatically converts to the single-cycle cranking feature (*1.a above*). This conversion prevents the starter motor from re-engaging during the second crank cycle in the event the engine is already running. *Also see section Microprocessor Program Notes.*

Time Delay Select

A combination Delay-On-Start and Cool-Down timing feature is available for programming into the microprocessor from the factory. This feature will delay the start-up of the engine for 3-seconds after the Remote Run contact is closed, and it will delay the shutdown of the engine for 3-minutes after the Remote Run contact is opened. This timing feature can be made active only in the “Auto” switch position, and still permits instantaneous manual starting in the “Run” switch position. Placing the selector switch in the “Stop” position provides instantaneous shut-down of the engine under all conditions. The start delay is intended to prevent unnecessary start-ups from momentary remote run signals, and the stop delay is intended to provide a cool-off running period for the engine after load removal.

Operating Instructions

Microprocessor Program Notes

Internal protection against loss of frequency input signal is programmed in after the unit has started normally. In the event the frequency goes to zero (engine runs out of fuel, frequency signal source fails, etc.), the LOP shutdown circuit is bypassed and a 12-second wait period is initiated. If the frequency returns within this time period, LOP monitoring resumes and operation continues normally. If frequency has not returned at the end of this time period, the engine oil pressure status is observed to determine whether the engine is actually running or stopped. If the engine has stopped, the cranking cycle will begin in an effort to re-start the engine. If the engine has not stopped (loss of input signal, etc.), the unit is shut down with an “overcrank” engine fault with alarm light indication.



Caution: “Overcrank” indication can mean a loss of frequency input signal during the previous run period. Attempting to re-start the engine without any frequency input signal can destroy the starter motor, which can cause serious personal injury. The frequency signal source is a key component in this system and must be checked out thoroughly whenever an “overcrank” shutdown occurs, since the control module only provides an indication of loss of signal during startup.

Resetting A Fault Shutdown

A shutdown with alarm, due to any fault condition, will prevent any subsequent operation of the generator set. The Run/Stop/Auto switch on the operator control panel must be momentarily placed in the “Stop” position to reset these functions.

Bouchette Electronics, Inc.

N11325 County Highway Y, Clintonville, WI 54929
(715) 823-7770 (715) 823-7771 Fax www.bouchette.com

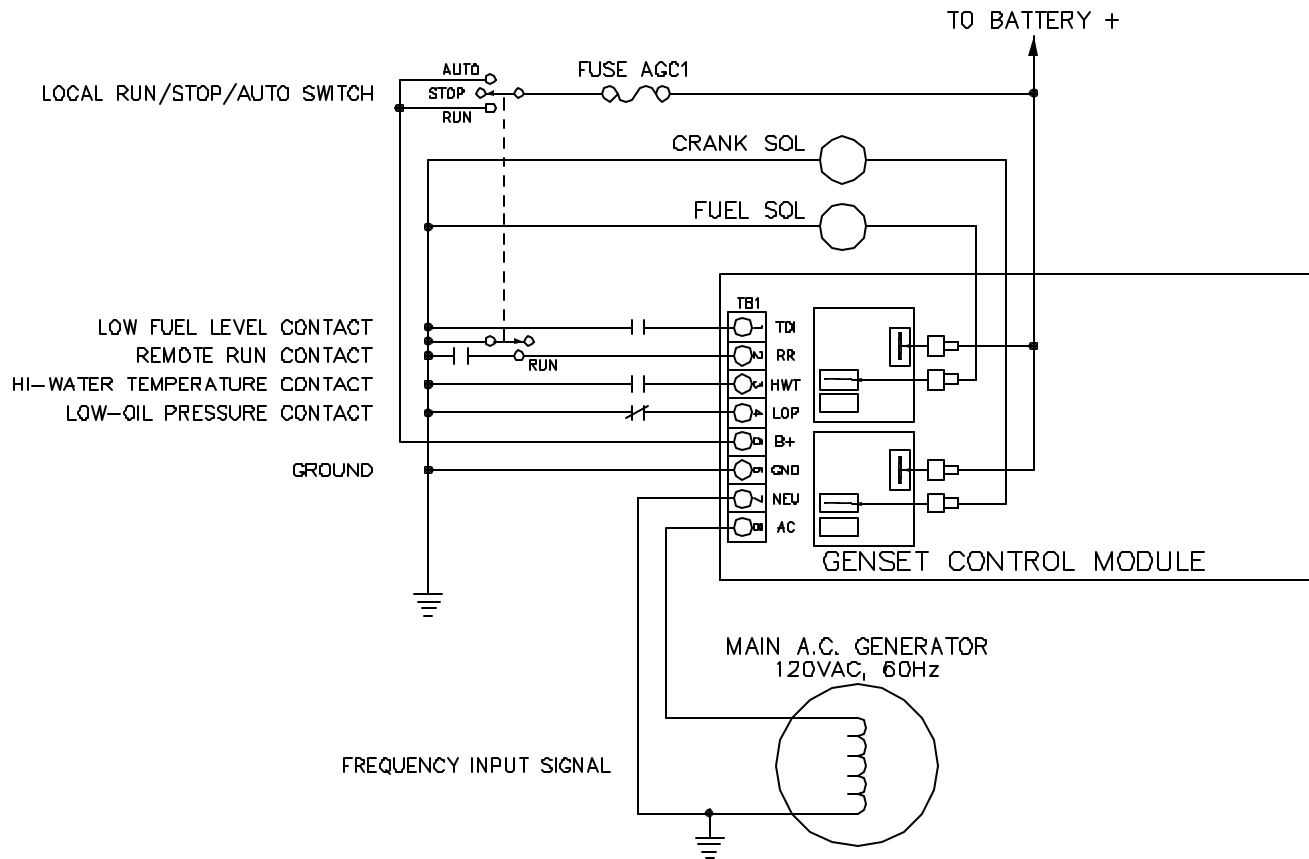

FREQUENCY SENSING FROM MAIN AC GENERATOR

REV	DATE	DESCRIPTION	DWN BY
A2	02/24/99	CHANGED AC INPUTS	DSB
A1	02/24/99	CHANGED LOP & HWT INPUTS	DSB

 Bouchette Electronics, Inc. N11325 County Highway Y Clintonville, WI 54929			
TITLE CONNECTION DIAGRAM B120C			
DATE	DWN BY	CHK	SCALE
08/22/97	DSB	TJB	NONE
P/N	CAD REF	DWG NO	
	PCB130	E195-1	